

Submittal Data Sheet

**Project
Information**

Project Number _____ Approval _____

Features

The Tri-Tech Area Alarm Panel digitally displays gas pressure (0.5 psi increments) and monitors and displays normal and alarm conditions for up to 7 medical gases. Transducers are included.

- Complies with NFPA 99. Made in the U.S.A.
- ETL Listed to UL-1069
- Self-contained unit - Designed for ease of installation and service.
- Microprocessor controlled
- Self-diagnostic and error message display for ease of maintenance.
- Audio and visual alarm indicators
- Bright easy to read L.E.D. displays – clearly visible in both day and night lighting conditions
- Constant display and monitoring of each gas
- User programmable high/low set points
- Dry contacts for remote monitoring of all alarm conditions on each gas module and on the CPU module for the entire panel
- Alarm history display of previous alarm conditions
- Easy to read – color coded gas modules
- Hinged frame for easy accessibility
- Optional interface to the hospital TNET alarm information management system.
- Three year PC board warranty
- All valves are dual gauge port full port ball valves
- 3 piece in-line repairable valves
- Adjustable packing with blowout proof stem design
- Accommodate up to 7 valves sizes from ½” to 2”
- Valves to have a working pressure of 600 psi (29 in/Hg vacuum)
- All valves cleaned for Oxygen service
- Plastic insulators to protect from galvanic corrosion
- Color coded labeling
- Provided with 1 ½” diameter gauges

Specification

All zone valve boxes shall be the Tri-Tech Medical Z D series and must be installed and tested in strict accordance with NFPA 99 standards and or any other local codes before use.

The alarm/ zone valve shall be the Tri-Tech Medical Integrated Area Alarm/ Zone Valve Panel. The panel shall be microprocessor controlled and designed to comply with NFPA 99. The panel shall be 100% digital and shall not require re-calibration. The unit shall be enclosed in a steel box and shall be designed to accept an electrical input range of 120-240 volts AC – 50-60 hertz. The source voltage shall be stepped down with a self-contained transformer. The panel shall contain audible and visual alarm indicators. The audible alarm may be silenced by pressing the alarm silence button, but the visual alarm indicator can only be cancelled by fault correction. The alarm shall detect and filter out transient (less than 0.6 seconds) signals created by R.F.I. The alarm shall be capable of displaying alarm history for all possible alarm conditions.

The alarm shall be capable of monitoring and displaying up to 7 gases per alarm panel. Gas modules can be arranged in accordance with the customer’s requirements.



In addition, each Area Alarm Module shall incorporate the following features:

- Does not require re-calibration
- Gas specific sensor with DISS nut & nipple. An error message will be displayed if incorrect sensor or no sensor is attached.
- User programmable pressure limits (Programmed from factory at 60/40 psig and 12 in Hg)
- Shall be capable of displaying gas readouts in PSI (in Hg), BAR or kPa, button selected.
- Gas alarm repeat feature factory set at 10 minutes, adjustable from 1 minute to 240 minutes, or off

Valves – The valves shall be dual gauge port, cast bronze, ball-type, with Teflon (TFE) seats and seals. All valves shall be rated at a working pressure of 600 psi (29 in/Hg vacuum) and shall be operated by a lever-type handle, requiring only a quarter turn from a fully open position to a fully closed position. Valves shall incorporate an adjustable packing and a blow-out proof stem. Only full port valves having flow rates comparable to equivalent size of pipe shall be used. Valves shall be piped from left to right.

All valves shall be provided with type K copper tubing extensions to facilitate installation. Valves shall be 3 piece in-line repairable type. Each valve assembly shall be supplied cleaned for oxygen service in accordance with current CGA standards. The valve tube ends shall be capped and sealed in a protective container to prevent contamination prior to installation.

Gauges shall be 1 ½” diameter for monitoring pressure and vacuum, and shall state: “USE NO OIL”. Dual scale gauges are not acceptable for the U.S.A. installations.

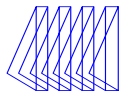

Box – The valve box shall be 18 gauge sheet steel construction painted to prevent rust. A single box shall house from one to seven valves. Box shall be supplied with an adjustable plaster flange 1/2” to 1 1/8” for easy mounting.

Window – Valve box assembly shall be supplied with a formed steel decorative frame painted white which encloses

an easily removable flexible window. The window shall be a “smoked” translucent flexible plastic with a pull-out ring pre-mounted to the center of the window. The window shall not be replaceable while any valve is in an open position. Window shall be silk screened with the following statement “CAUTION: MEDICAL GAS SHUTOFF VALVES. CLOSE ONLY IN EMERGENCY.”

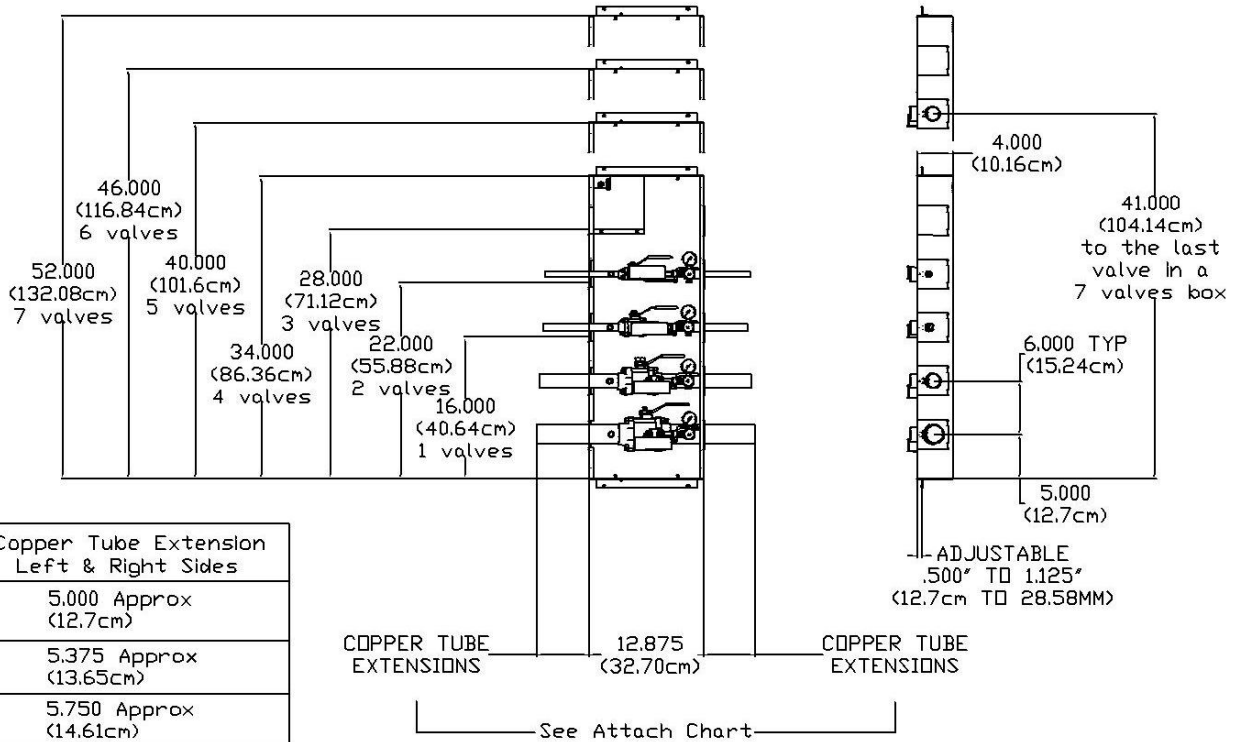

Valve Size	Copper Tube Extension Left & Right Sides
1/2", 3/4" 1", 1-1/4"	5.000 Approx (12.7cm)
1-1/2"	5.375 Approx (13.65cm)
2"	5.750 Approx (14.61cm)

Rough Opening Height Dimension for "X"

	IN	CM
1 valves	16.125	40.96
2 valves	22.125	56.20
3 valves	28.125	71.44
4 valves	34.125	86.68
5 valves	40.125	101.92
6 valves	46.125	117.16
7 valves	52.125	132.40

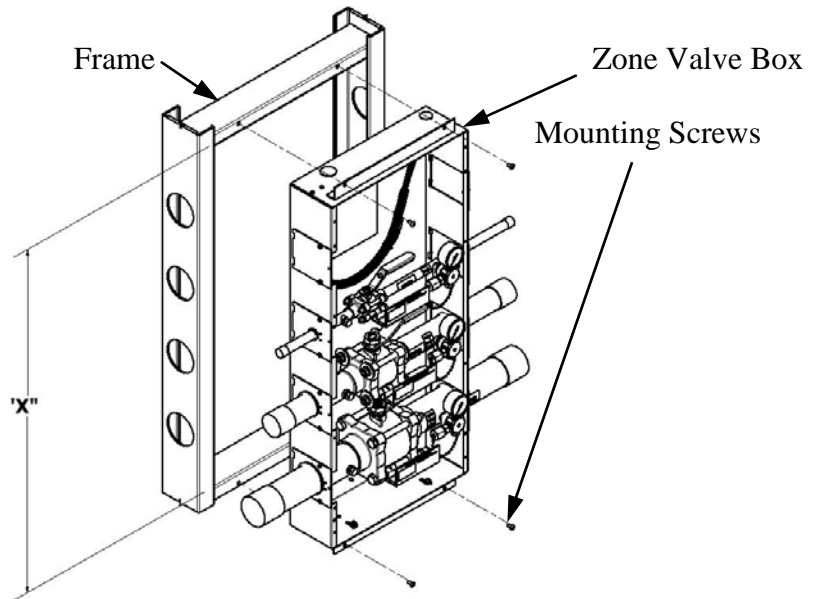

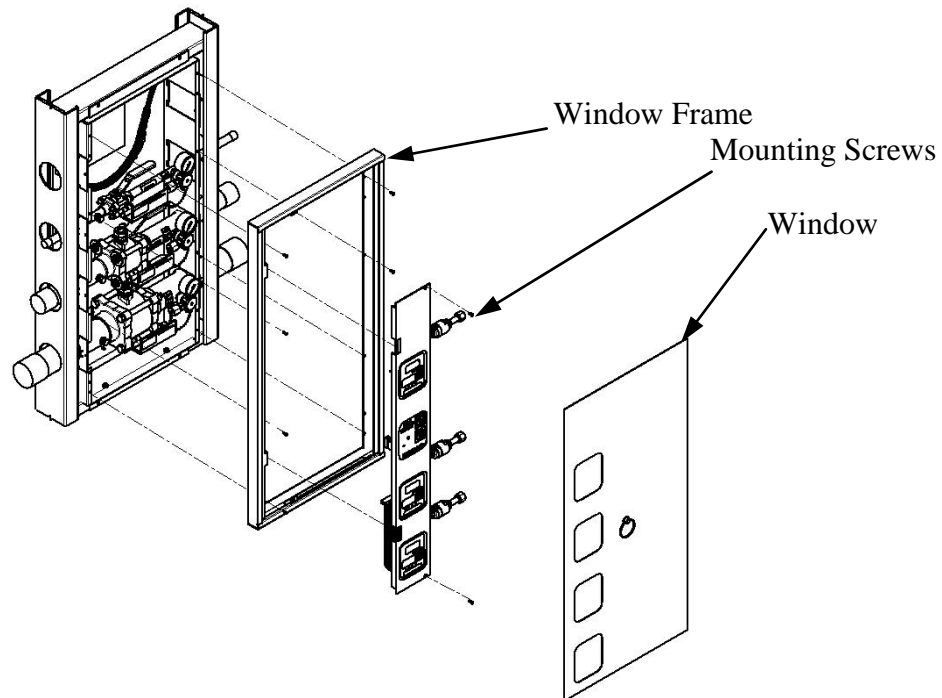
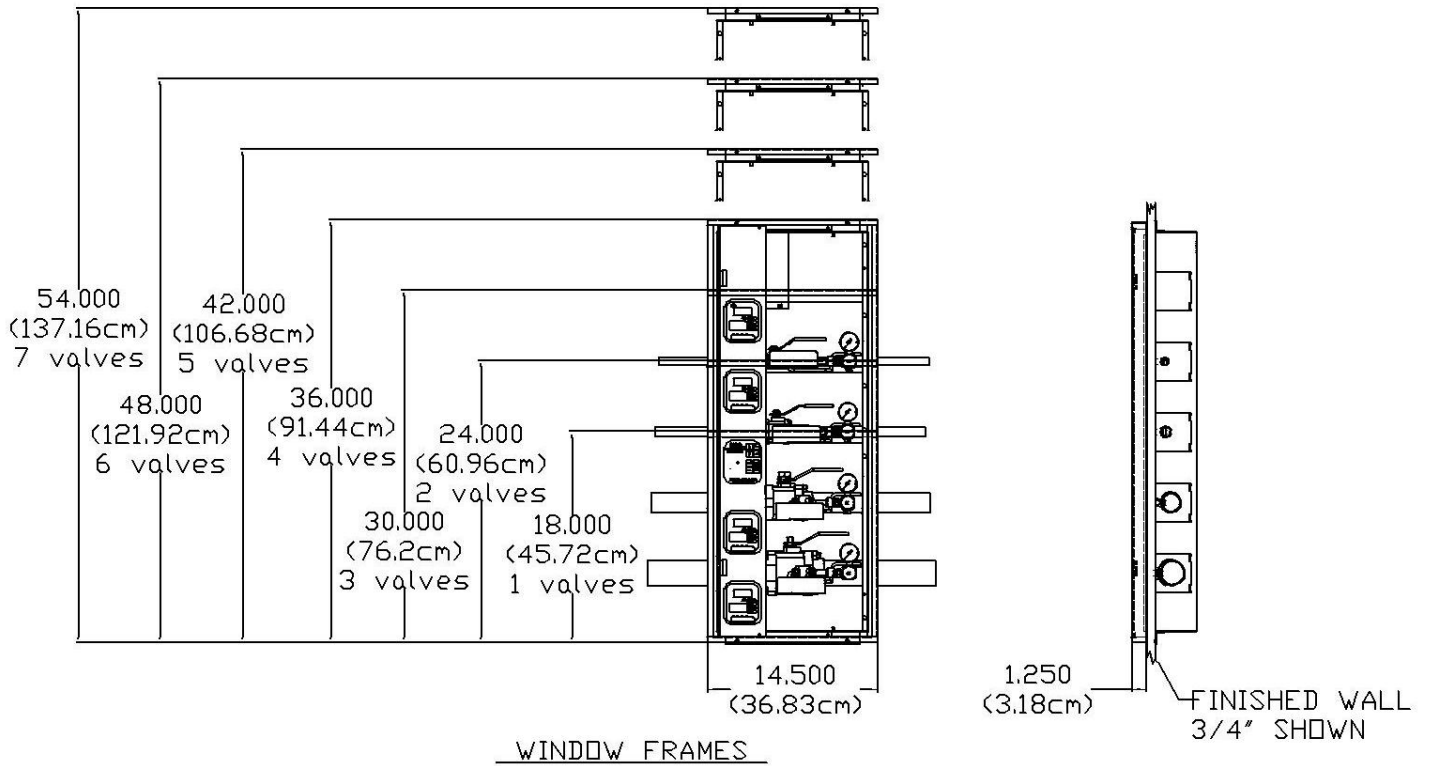
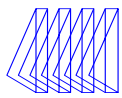

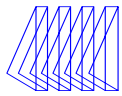

How to Order: Easy to use modular ordering system.

Fill in the blanks to specify the Zone Valve that meets *your* needs.

